

Schlüter®-DILEX-EP

Movement joint profile
for the screed laying process

4.5

Product data sheet

Application and Function

Schlüter®-DILEX-EP is a prefabricated movement profile for the installation of bonded screeds or screeds over a separating layer (floating screeds). The side sections are made of recycled rigid PVC with a top and bottom connection made of soft CPE. The profile is positioned in such a way that it will be in direct alignment with the surface movement joint placed later during tile installation. The top edge of the Schlüter®-DILEX-EP serves as an ideal screeding guide for the screed surface. Furthermore, the profile is suited for use in self-levelling screeds. Schlüter®-DILEX-EP's side flanges anchor the profile to the screed. The soft movement zone absorbs compressive, tensile, and shear stresses.

Material

Schlüter®-DILEX-EP consists of side sections made of recycled rigid PVC with a top and bottom connection made of soft CPE acting as a movement zone.

Material properties and areas of application

The profile is resistant to most chemicals encountered in tiled environments.

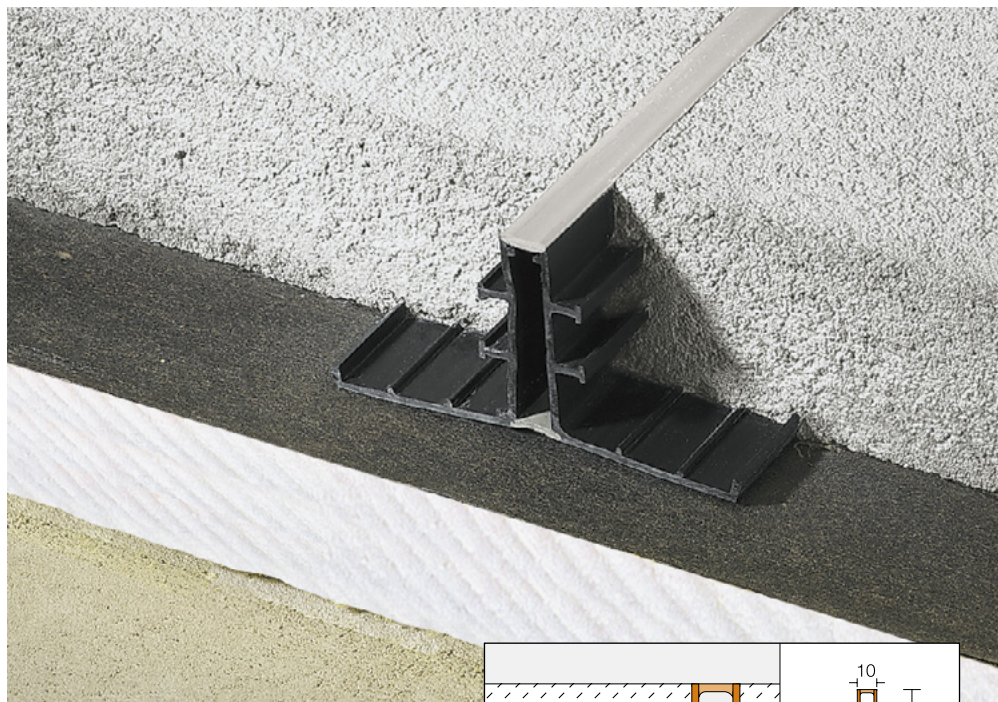

In special cases, the suitability of a proposed type of material must be verified based on the anticipated chemical, mechanical, and/or other stresses. The profile's CPE movement zones are UV-resistant and contain no softeners.

Schlüter®-DILEX-EP is installed as a movement joint in screeds and self-levelling screeds. The profile separates individual covering fields and equalizes occurring compressive, tensile, and shear stresses in the soft CPE movement zone.

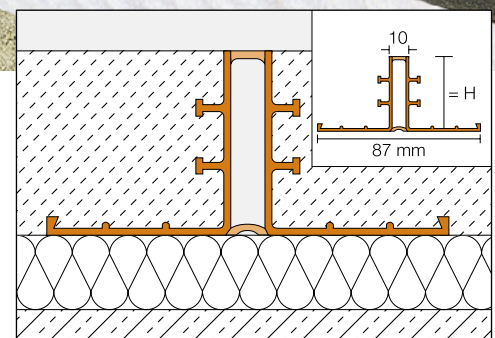



Installation

1. Place Schlüter®-DILEX-EP on the substrate and adjust according to height and alignment (congruent to the surface movement joint later installed in the tile.)
2. If the height needs adjustment, place a thin layer of mortar or other suitable base underneath.
3. Secure profile with mortar to prevent movement. The top edge of the profile also serves as a screeding guide for the screed surface.

Maintenance

Schlüter®-DILEX-EP is resistant to fungi and bacteria and requires no special maintenance.

Text template for tenders:

Supply
 _____ per metre Schlüter®-DILEX-EP as a screed movement profile consisting of side sections made of recycled rigid PVC with integrated side flanges, connected at the top and bottom with a soft CPE movement zone, to be used when preparing bonded screeds or screeds over separating layers, and solidly embed into the screed mortar via the side flanges. Adjust profile according to height and alignment, congruent to the surface movement joint later installed in the ceramic covering. Otherwise, follow manufacturer's specifications.

Profile height: _____ mm
 Art. -No.: _____
 Material: _____/m
 Labour: _____/m
 Total: _____/m



Product Overview

Schlüter®-DILEX-EP

Screed movement profile

Length supplied: 2.50 m

Height	EP
H = 30 mm	•
H = 40 mm	•
H = 50 mm	•